

Debug Specification of Synchronous

1. Wiring Diagram

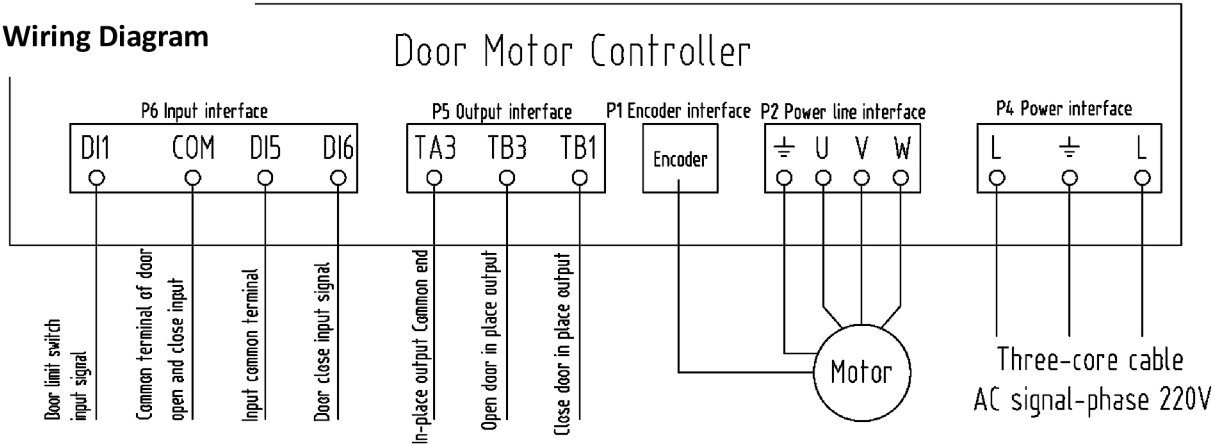

2. Product Exterior Overview

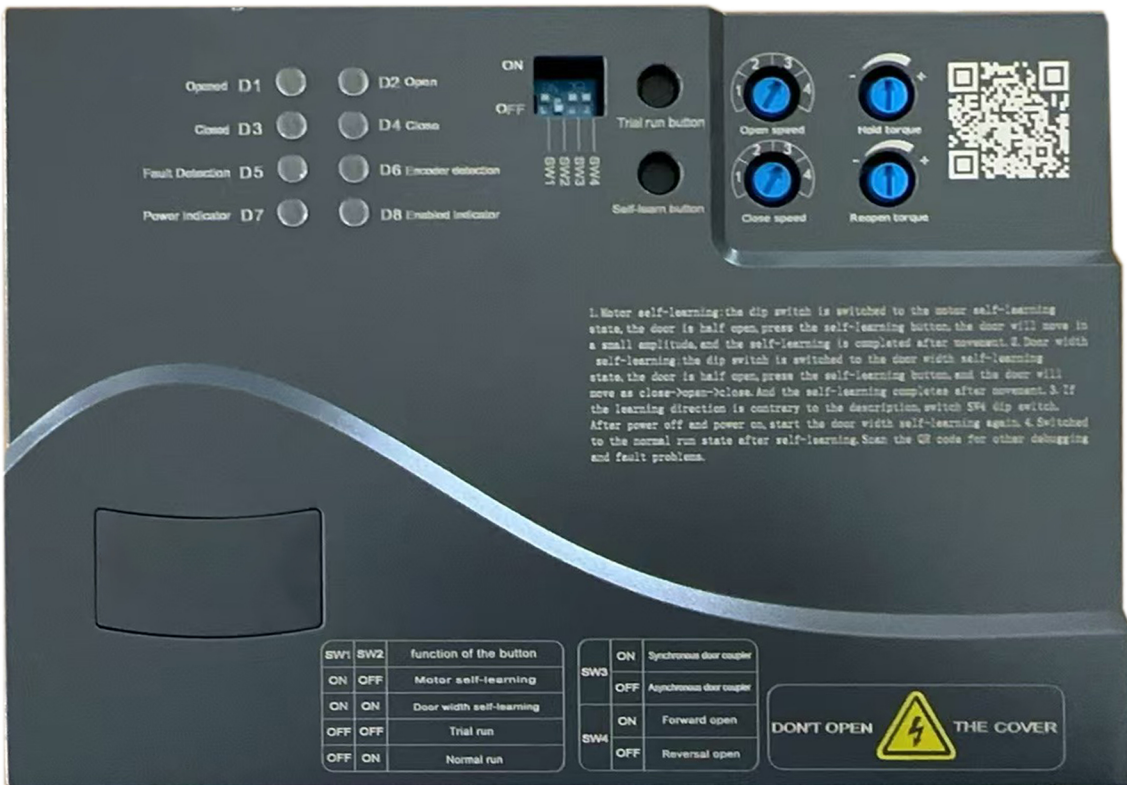

Note: Description of each part on the diagram

Opened: Light on when door is opened. Converter outputs signal of door opened

Closed: Light on when door is closed. Converter outputs signal of door closed

Fault detection: Light on when fault occurred.

Power indicator: Light on when power supply works normally.

Open: Light on when there is open signal.

Close: Light on when there is close signal.

Encoder detection: Detect working status of encoder

Enabled indicator: Light on when current outputted.

SW1-SW2 dial switches: Switches for function selection of angle self-learning, door width self-learning, normal operation and test operation.

SW3dial switches: Switch the door vanes, ON is synchronous vane, OFF is asynchronous vane.

SW4dial switches: Switch opening and closing direction.

Trial run button and Self-learn button: Buttons for functions of angle self-learning, door width self-learning, normal operation and test operation.

Knob of door opening speed: divided into Gear 1 to Gear 4 and switch the door open speed

Knob of door closing speed: divided into Gear 1 to Gear 4 and switch the door close speed

Torque holding speed: keep the door open and close holding torque through switching the knob

Torque knob of door re-opening: switch the door re-opening torque through switching the knob

3. Procedures of debugging

Note: The parameters have been set in default in manufacturing. After the door machine is installed, the test operation can only be done after motor angle self-learning and door width self-learning.

3.1 Motor angle self-learning

Switch SW1 ON and SW2 OFF, place the door-motor to the half-open place, press knob of self-learning and then the door moves in small width. Self-learning is finished after movements.

3.2 Door width self-learning

Switch SW1 ON and SW2 ON, place the door-motor to the half-open place, press knob of self-learning and then the door starts to move. The direction is: door close, close to the limit, door open, open to the limit, door close, close to the limit and the self-learning is finished. If the learning direction goes against to the description, please switch SW4.

3.3 Trial Run

Turn SW1 OFF and SW2 ON. Shortly connect DI5 and COM and then door open. The panel light will be on when the door opens to the limit. Shortly connect DI6 and COM and then door close. The panel light will be on when the door closes to the limit. If the test run direction goes against to the description, please switch SW4 and repeat the trail run for more than 5 times.

3.4 Automatic opening and closing demonstration

SW1 dial OFF , SW2 dial OFF. Press the “trial running” button to perform the function of automatic opening and closing. At this time, in the non-level zone, you need to manually pull up the car lock every time the door is opened. After checking that the running curve of door opening and closing is normal, SW2 dial ON, switch the inverter into the mode of normal running.

4. Factory status

When the trail run is finished, please place the door open speed on Gear 3 and door close speed on Gear 3. Keep the holding-torque knob in the middle place and door re-open torque knob in the middle place.

5. Alarm indicator display

Alarm Code	OC	Ph1	LU	OL	EC	EH	OS
Indicator code	D5	D1 D3 D4 D5	D3 D5	D1 D3 D5	D5 D6	D2 D5	D1 D2 D5
Alarm Code	LE	dE	anE	Act	Pol	HU	OC2
Indicator code	D2 D3 D5	D1 D2 D3 D5	D4 D5	D1 D4 D5	D3 D4 D5	D1 D5	D2 D4 D5

6. Alarms Troubleshooting

Alarm Code	Fault Name	Operation state	Possible Causes	Solutions
OS	Over-speed	Emerged during drive energizing	Drive circuit error drive	replace drive
			Encoder error	Replace door motor
		Emerged in motor start-ups	Encoder default angle error	Learning default angle again
			Motor U,V,W phase sequence error	Check and make sure it has been wired correctly
			Encoder leads error	
		Emerged during motor operation	Encoder error	Replace door motor
Mis-adjustment of door motor system parameters cause overshoot	Reset the gain parameters of regulator.			
HU/POL	Main circuit overvoltage Main circuit power failure	Emerged during energizing	Internal circuit board of drive error	Replace door motor drive
			Power is overvoltage	Check if supplied power is excessive
		Emerged during motor operation	Internal braking transistor of drive is damaged	Replace door motor drive
		Emerged during main circuit power failure	Report POL in normal circumstances	
LU	Main circuit under-voltage	Emerged during energizing	Loose connection of main power line	Check if lines are connected firmly
			Power supply is unstable and has low voltage	Check if power supply is stable
			Momentary outage longer	Check power supply

			than 20ms	
			Drive internal components error	Replace servo drive
		Emerged during motor operation	Instant power-off	Check power supply
EC	Encoder communication abnormality	Emerged during energizing	Encoder cable error	Check if encoder wiring is correct and if lines are broken
			Loose contact of encoder lines	Check if encoder lines are connected firmly
			Encoder damaged	Replace door motor
			Drive circuit is internally detected error	Replace door motor drive
EH	Current sampling loop damaged	Emerged during energizing	Internal current sampling loop of drive is damaged	Replace door motor drive
OL	Overload	Emerged during energizing	Internal circuit of drive is error	Replace door motor drive
		Emerged during motor operation	Operated with excessive torque	Check loads
			Wrong connection of drive U,V,W power lines	Check if U,V,W power lines are connected correctly
			Abnormal door motor	Replace door motor
OC	Overcurrent	Emerged during energizing	Internal circuit of drive damaged	Replace door motor drive
		Emerged during motor operation	Short circuit among U,V,W power lines	Check power lines
			Wrong control loop parameters	Reset control loop parameters
			Current output is excessive	Decrease parameter of current upper bond
			Poor grounding and external disturbance	Grounding correctly
			Internal circuit of drive damaged or phase shortage	Replace drive
OC2	Overcurrent2	Emerged during motor operation	Drive error	Replace drive
PHL	Phase shortage	Emerged during motor startups	Protective tube of bus line fused	Replace protective tub
			Phase-shortage of UVW	Check connection of power

			power line	line
			Abnormal motor	Replace motor
		Emerged during motor operation	Protective tube of bus line fused	Replace protective tub
			Phase-shortage of UVW power line	Check connection of power line
DE	Door width error	Emerged during door width self-learning	door motor operation path hindered	Clear hindrance and restart self-learning function
			Abnormal motor	Replace motor
		Emerged during first time low-speed operation	Wrong door width data	Check if door width parameter PN20 is proper, restart self-learning function
			door motor	Clear hindrance and restart
			Abnormal motor	Replace motor
AnE	Default angle error	Emerged during default angle learning	overload	Reduce load and restart
			Operation path hindered and motor blocked	Clear hindrance and restart
			Abnormal motor and encoder	Replace motor
Act	Door open action failed	Emerged during door open	Operation path hindered	Cut off the power and check hindrance. Clear hindrance and restart the operation with power on.
			Wrong door width data	Cut off the power and check hindrance. Restart door width self-learning function with power on
LE	Without self-learning failure	The motor is just running	The drive does not run directly through angle self-learning	Re-angle self-learning and door width self-learning